

# PIPE STANDS

Pipe Handling for 2" IPS through 65" OD pipe (63mm to 1600mm)



McElroy 2065 Pipe Stand



McElroy Heavy-Duty Pipe Stand



McElroy 14 Pipe Stand

## OVERVIEW

McElroy Pipe Stands save wear and tear on machinery, reduce strain on operators and makes the fusion process easier. Pipe stands are adjustable for uneven terrain so that the pipe is supported at the same height as the machine. By bringing the pipe in parallel to the machine, it is much easier to adjust high/low and achieve a square face-off.

When building a pipeline, pipe stands can greatly increase productivity. Instead of moving the machine for each joint, you can pull the fused pipe through the machine and roll in a new stick to be fused. This allows you to stage all the pipe in one location, and keep the fusion machine stationary, minimizing down time between fusion joints.

## FEATURES

- Adjustable for uneven terrain
- Enhances productivity
- Saves wear and tear on fusion machine
- Easier fusion process

## SPECIFICATIONS

MODELS	PART NO.	APPLICABLE FUSION MACHINES	MAXIMUM LOAD	NOTES	WEIGHT
14 Pipe Stand.....	422801.....	Pit Bull® 14.....	2,500 lbs. (1,134 Kg).....	For use with the Manual Fusion Machine Stand.....	37 lbs. (16.8 Kg)
28 Pipe Stand.....	812501.....	Pit Bull® 14, Pit Bull® 26, 28s and 250s.....	2,500 lbs. (1,134 Kg).....	When used with 14 and 26, use Manual Fusion Machine Stand.....	64 lbs. (29 Kg)
412/618 Pipe Stand.....	1223201.....	412s, 618s and 500s.....	2,750 lbs. (1,247 Kg).....	N/A.....	130 lbs. (59 Kg)
824 Pipe Stand.....	2429101.....	824s.....	4,500 lbs. (2,041 Kg).....	N/A.....	197 lbs. (89 Kg)
TracStar® 900 Pipe Stand.....	T9017401.....	824s, 630s, 1236s and 900s.....	4,500 lbs. (2,041 Kg).....	N/A.....	155 lbs. (70 Kg)
Heavy-Duty Pipe Stand.....	4823901.....	824s, 630s, 1236s, 900s and 1648s.....	6,500 lbs. (2,948 Kg).....	N/A.....	595 lbs. (270 Kg)
2065 Pipe Stand.....	6314001.....	2065s and 1600s.....	11,000 lbs. (4,989 Kg).....	N/A.....	1,025 lbs. (465 Kg)

### INCLUSIONS

Specifications subject to change without notice.

051811

# MEGAMc<sup>®</sup> PIPE STANDS

Job Site Productivity for 8" to 36" (225mm to 900mm) and 36" to 65" (900mm to 1600mm)



## OVERVIEW

Most job sites require heavy machinery to lift and hold a length of pipe in place for large-diameter fusion projects. To free up some of the heavy machinery's time and save money, the new self-contained, gasoline-powered MegaMc<sup>®</sup> Pipe Stands help align the pipe with the fusion machine, and then hold the pipe at the proper height.

The Pipe Stand doesn't burn through gasoline either. Simply start the engine to adjust the pipe up to 24" laterally and 34" vertically, then turn the HPU off and the height you determine locks in place. Since the unit is self-contained, there are no hydraulic hoses running across the site. Rugged rollers with low-friction pillow block bearings allow the pipe to move easily through the rollers.

Two models are available for use on most medium and large diameter job sites, with a smaller unit that works with 8" to 36" pipe. A larger unit handles pipe from 36" to 65".

## FEATURES

- Two models accommodate pipe sizes from 8" to 65" (225mm - 1600mm)
- Self-contained, gasoline-powered HPU means no hydraulic hoses are running across the job site.
- 5.5 Horsepower
- Adjustable while fully loaded, up to 24" laterally and 34" vertically
- Height locks in place, even with HPU turned off
- Features rugged 6.625" diameter rollers with low-friction pillow block bearings
- Wide base for stability
- Can be picked up by forklift or crane, also stackable

## SPECIFICATIONS

### MODELS

3645001:.....	8" to 36" (225mm to 900mm)
6513501:.....	36" to 65" (900mm to 1600mm)

### MAXIMUM CAPACITY

8" to 36" (225mm to 900mm) Pipe Stand:.....	9,000 lbs. (4,082 Kg)
36" to 65" (900mm to 1600mm) Pipe Stand:.....	16,000 lbs. (7,257 Kg)

### WEIGHT

8" to 36" (225mm to 900mm) Pipe Stand:.....	2,160 lbs. (980 Kg)
36" to 65" (900mm to 1600mm) Pipe Stand:.....	3,025 lbs. (1,372 Kg)

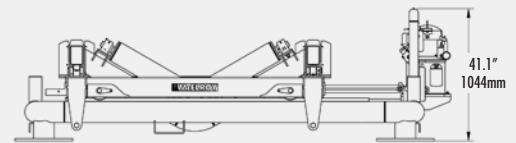
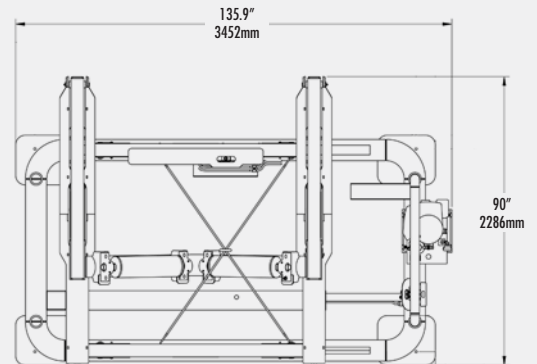

**36" - 65" MegaMc Pipe Stand**

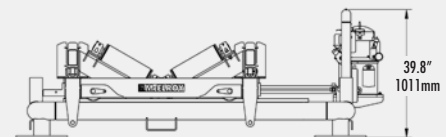
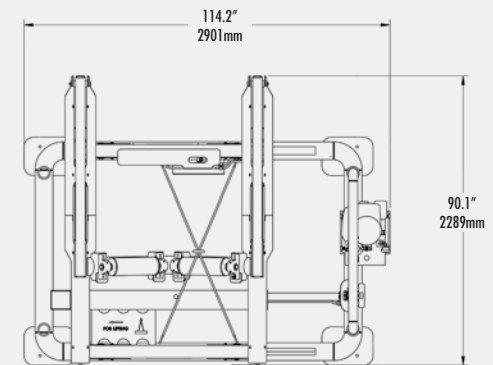

**8" - 36" MegaMc Pipe Stand**

### INCLUSIONS

Specifications are subject to change without notice.