

MiniMc Fusion Machine

Fusion Capability for 1/2" CTS – 1" IPS (16mm – 34mm)

Patent No. 4,484,975



MiniMc™

McElroy's smallest fusion machine, the **MiniMc™**, makes small diameter butt fusion projects simple. They are compact, lightweight, highly reliable, accurate and rugged. Perfect for joining **1/2" CTS to 1" IPS (16mm to 34mm)** service sizes. The MiniMc requires only one operator and works in the most difficult conditions. McElroy's patented features and precision engineering provide joint integrity and minimal maintenance. The narrow clamp design provides for butt fusion with

precise pipe alignment at the fusion joint. The heater is thermostatically controlled and has a durable anti-stick coating.

- Compact, lightweight
- Hand-operated
- Thermostatically controlled heater
- 2.3-to-1 mechanical advantage

MiniMc

Machine Size	Model No.
Includes fusion machine and screw/driver kit. Heater, facer, and inserts are sold separately.	
1" IPS MiniMc	CTS07901
32mm MiniMc	CTS08001

INTRODUCING THE 11C

Are you fusing from above? Working in-ditch? Check out the new 11C, which fuses the same sizes as the MiniMc. **See page 12 for more details.**

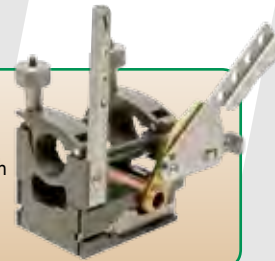

MACHINE PLUG TYPE
To find the right electrical plug type see **Page 139**

GENERATOR
To size your generator see **Page 145**

ACCESSORIES
To find other related accessories see **Page 127**



Visit the Fusion Experts at www.mcelroy.com

MiniMc

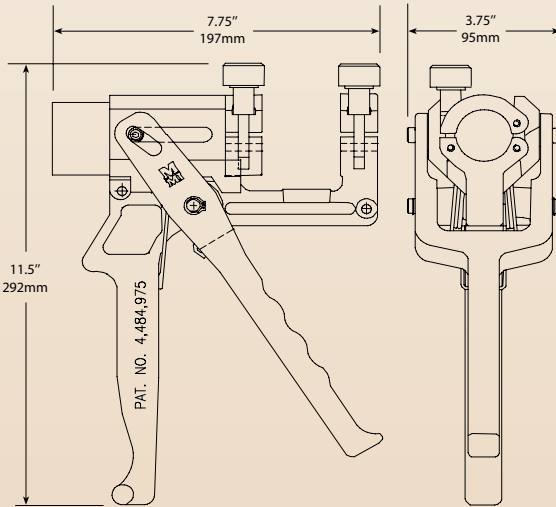

CAPACITY

Fuses Pipe Sizes: ½" CTS – 1" IPS (16mm – 34mm)

WEIGHT

Machine: 3.5 lbs (1.6Kg)
 Heater: 3.24 lbs (1.47Kg)
 Ratchet Facer: 0.54 lbs (0.24Kg)
 Knurled Facer: 0.25 lbs (0.11Kg)

POWER

Heater Power: 300 Watt
 Facer Power: Hand-operated

WARRANTY

Term: 3 Years, see page 5 for details

Specifications subject to change without notice.

Part No.	Description
----------	-------------

Heaters - See legend below for more information.



A	CTS00702	100-120V, 50/60Hz, 300 Watt, 1Ph
C	CTS00703	200-240V, 50/60Hz, 300 Watt, 1Ph

Insulated Heater Sling



CTS08301	Protects heater and helps maintain a constant temperature.
----------	--

Ratchet Facer



CTS15014	This facer is designed for increased leverage.
----------	--

Knurled Facer



CTS01701	This facer is designed for compact use.
----------	---

Spare Facer Blade Set



CTS06803	Set of two spare facer discs. Compatible with either facer and made of hardened steel.
----------	--

Spare Screw/Driver Kit



ACTS08201	Spare driver kit with insert screws and wire brush for cleaning serrated jaws and inserts.
-----------	--

Tubing Shear



MMD00009	Used to cut plastic tubing only, up to 1.7" OD capacity.
----------	--

Part No.	Description
----------	-------------

Pyrometer Kit



A218804	Accurately checks surface temperatures of heater.
---------	---

MiniMc Case



MJQ00032	Our strong and durable carrying case will hold a MiniMc, heater, heater sling, facer, inserts, tubing shear, and other miscellaneous items.
----------	---

MiniMc Facer Insert Set - Set = 2 inserts



Facer insert sets must be selected for each pipe size. Compatible with either facer.

CTS15017	1" IPS	1.32" OD
CTS15019	1" CTS	1.13" OD
CTS15020	¾" IPS/27mm	1.05" OD
CTS15021	¾" CTS	0.88" OD
CTS15022	½" IPS	0.84" OD
CTS15018	½" CTS	0.63" OD
CTS15030	34mm	1.34" OD
CTS15028	32mm	1.26" OD
CTS15026	25mm	0.98" OD
CTS15024	20mm	0.79" OD

Butt Fusion Insert Set - Set = 4 inserts, screws & wrench





Inserts are serrated for maximum grip and are made for one size pipe only. Inserts are required for pipe sizes less than 1" IPS or 32mm.

CTS07101	1" CTS	1.13" OD
CTS07201	¾" IPS	1.05" OD
CTS07301	¾" CTS	0.88" OD
CTS07401	½" IPS	0.84" OD
CTS07501	½" CTS	0.63" OD
CTS09201	25mm	0.98" OD
CTS09301*	25mm	0.98" OD
CTS09101	20mm	0.79" OD
CTS13501*	20mm	0.79" OD

* For use with CTS08001

HEATER PLUG TYPE LEGEND

See page 139 for more details.

-  Plug type A
-  Plug type C