

DynaMc™ 412 Fusion Machines

Fusion Capability for 4" IPS – 12" DIPS pipe (110mm – 340mm)

Machine Type	Model No.	Cylinder Force	Facer Voltage Requirements	Heater Voltage Reqs.	Min. Power Reqs. *	Plug Type **
--------------	-----------	----------------	----------------------------	----------------------	--------------------	--------------

DynaMc 412 HP

Includes fusion carriage, facer, facer stand, heater and insulated heater stand. Facer/Heater



2-Jaw DynaMc HP Pictured

2 Jaw	A1263601	Low	100V-120V, 50/60Hz, 1Ph	220V-240V, 50/60Hz, 1Ph	4.2KVA, 4.2KW	A/C
	A1263602	Low	220V-240V, 50/60Hz, 1Ph	220V-240V, 50/60Hz, 1Ph	4.2KVA, 4.2KW	C/C
4 Jaw	A1262901	Low	100V-120V, 50/60Hz, 1Ph	220V-240V, 50/60Hz, 1Ph	4.2KVA, 4.2KW	A/C
	A1262902	Low	220V-240V, 50/60Hz, 1Ph	220V-240V, 50/60Hz, 1Ph	4.2KVA, 4.2KW	C/C

Machine Type	Model No.	Cylinder Force	Facer Voltage Requirements	Heater Voltage Reqs.	Min. Power Reqs. *	Plug Type **
--------------	-----------	----------------	----------------------------	----------------------	--------------------	--------------

DynaMc 412 EP

Includes fusion carriage, facer, facer stand, heater and insulated heater stand. Electric Pump is sold separately. Facer/Heater



4-Jaw DynaMc EP Pictured

2 Jaw	A1274901	Low	100V-120V, 50/60Hz, 1Ph	220V-240V, 50/60Hz, 1Ph	4.2KVA, 4.2KW	A/C
	A1274902	Low	220V-240V, 50/60Hz, 1Ph	220V-240V, 50/60Hz, 1Ph	4.2KVA, 4.2KW	C/C
4 Jaw	A1274801	Low	100V-120V, 50/60Hz, 1Ph	220V-240V, 50/60Hz, 1Ph	4.2KVA, 4.2KW	A/C
	A1274802	Low	220V-240V, 50/60Hz, 1Ph	220V-240V, 50/60Hz, 1Ph	4.2KVA, 4.2KW	C/C

Machine Type	Model No.	Input Voltage Requirements	Minimum Power Requirements *	Plug Type **
Electric Pump (HPU)	1272701	120V, 60Hz, 1Ph	1.56KVA, 1.25KW	A
	1272702	208V-240V, 60Hz, 1Ph	1.56KVA, 1.25KW	C
	1272703	220V-240V, 50/60Hz, 1Ph	1.65KVA, 1.24KW	M
	1272704	100V, 50/60Hz, 1Ph	1.65KVA, 1.24KW	B

Machine Type	Model No.	Cylinder Force	Input Voltage Requirements	Minimum Power Requirements *	Plug Type **
--------------	-----------	----------------	----------------------------	------------------------------	--------------

DynaMc 412 Auto

Includes auto power unit, control unit, carriage, facer, facer stand and heater assembly



4 Jaw Automatic	A1252701	Low	110V-120V, 50/60Hz, 1Ph	3KVA, 3KW	N
4 Jaw Automatic	A1252702	Low	220V-240V, 50/60Hz, 1Ph	3KVA, 3KW	N

- * This is the minimum generator requirement at sea level, see your generator supplier or refer to the generator sizing form on page 145.
- ** Refer to the plug type reference chart on page 139 for your correct plug type.

Part No.	Description
----------	-------------

Spare 4.63" Facer Blade Set - 6 blades, screws and wrench



Economical blade must be positioned for different pipe sizes.	
T1208603	Standard blades.
T1208603C	Extended-life blades.

Spare 6.13" Facer Blade Set - 6 blades, screws and wrench



Spans the entire facer range without repositioning.	
T1208610	Standard blades.
T1208610C	Extended-life blades.

Spare Heater Plate Kit

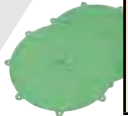

A1242108	Set of 2 plates with anti-stick coating required for butt fusion. Kit includes attaching screws and wrench.
----------	---

Low Profile Rollers - To learn more, see page 104

NEW!



A1867501	Aids by reducing the drag on the pipe and protecting the pipe from damage. Case includes 40 complete roller assemblies.
----------	---

DataLogger® - To learn more, see page 108



Used to record and document fusion process parameters.	
DL6303	Wireless DataLogger
DL6304	Wired DataLogger

NEW!

Spare Heater 220-240V, 50/60Hz, 1Ph



1242112	Microprocessor-controlled with dial thermometer to monitor temperature. Includes heater plates insulated heater stand and stripper bars.
---------	--

Stub End Holder - To learn more see page 114

NEW!



1270101	Self-centering stub end holder to hold stub end for butt fusion.
---------	--

Part No.	Description
----------	-------------

Pyrometer Kit



A218804	Accurately checks surface temperatures of heater.
---------	---

Spare Facer Stand



T1201101	Facer stand provides a convenient place to protect and store your facer out of the dirt and mud.
----------	--

Heat Shield



203007	For fusing two materials with different melt rates. Shields the faster melt rate materials from over melting.
--------	---

Part No.	Description
----------	-------------

Auto-Only Accessories

Spare DynaMc Auto Power Box Assembly



Spare Auto power unit for use with DynaMc 250 and 412 Auto.	
1267301	110V-120V
1269401	220V-240V

Spare DynaMc Auto Operator Control Box



1266701	Spare Control Box for use with DynaMc Auto 250 and 412.
---------	---

Spare DynaMc 412 Auto 120V Heater Assembly



1256001	Spare heater for the DynaMc 412 Auto.
---------	---------------------------------------

Spare DynaMc 412 Auto 240V Heater Assembly



1260101	Spare heater for the DynaMc 412 Auto.
---------	---------------------------------------

DynaMc™ 412 Butt Fusion & Mitered Inserts

Butt Fusion Inserts

Our cast inserts have been surface-hardened for longer life. All inserts are serrated for maximum grip on the pipe. Inserts are made for one size pipe only. Not all inserts fit directly in the jaws. Some inserts nest inside other inserts, called master inserts.

NOTE: Other sizes of inserts are available upon request. Contact your McElroy representative about inserts to fit your needs.

For JIS insert sizes, see page 126.

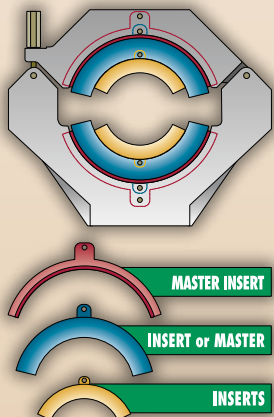

Mitered Inserts

Mitered inserts are used to fabricate segmented ells. Our standard miter is 11¼°, other mitered angles are available upon request.

Standard Ell Configuration
90° Ell 11¼° miter shown

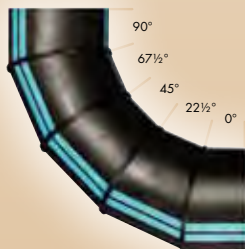

All inserts below fit in 12" DIPS 13.20" (335mm) Jaws

Inserts	Pipe OD	2 Jaw Sets	4 Jaw Sets
12" IPS/DIPS Master	12.75 (324mm)	Inc w/pkg	Inc w/pkg

All inserts below require 12" IPS/DIPS Master insert

315mm	12.40 (315mm)	1211206	1211202
10" DIPS	11.10 (282mm)	1207231	1207221
280mm	11.02 (280mm)	1207230	1207205
10" IPS	10.75 (273mm)	1207229	1207204
250mm	9.84 (250mm)	1213512	1213503
8" DIPS	9.05 (230mm)	1207109	1207107
225mm	8.86 (225mm)	1207046	1207010
8" IPS	8.63 (219mm)	1207108	1207104
200mm	7.87 (200mm)	1207045	1207009
7.125" OD/180mm	7.13 (181mm)	1207044	1207008
6" DIPS	6.90 (175mm)	1207048	1207020
6" IPS Master	6.63 (168mm)	1207043	1207007
160mm	6.30 (160mm)	1207047	1207011

All inserts below require 6" IPS' & 12" IPS/DIPS Master inserts

5" IPS	5.56 (142mm)	809435	809409
140mm	5.51 (140mm)	809439	809428
5.375 OD	5.38 (137mm)	809437	809411
5.25 OD	5.25 (133mm)	809436	809410
125mm	4.92 (125mm)	809438	809413
4" DIPS	4.80 (122mm)	809327	809315
4" IPS/100mm JIS	4.50 (114mm)	809434	809408
110mm	4.33 (110mm)	809324	809305

11¼° Mitered Inserts Set = 4 Inserts & 1 Template

All inserts below fit in 12" DIPS 13.20" (335mm) Jaws

Inserts	Pipe OD	Set No.
12" IPS/DIPS Master	12.75 (324mm)	Inc w/pkg

All inserts below require 12" IPS Master insert

280mm x 11.25	11.02 (280mm)	1214284
10" IPS x 11.25	10.75 (273mm)	1214232
250mm x 11.25	9.84 (250mm)	1214235
8" DIPS x 11.25	9.05 (230mm)	1214269
225mm x 11.25	8.86 (225mm)	1214281
8" IPS x 11.25	8.63 (219mm)	1214230
200mm x 11.25	7.87 (200mm)	1214234
180mm x 11.25	7.13 (180mm)	1214290
6" DIPS x 11.25	6.90 (175mm)	1214275
6" IPS x 11.25	6.63 (168mm)	1214228
160mm x 11.25	6.30 (160mm)	1214239
5" IPS/140mm x 11.25	5.56 (141mm)	1214242
125mm x 11.25	4.92 (125mm)	12142108
4" DIPS x 11.25	4.80 (122mm)	1214287
4" IPS x 11.25	4.50 (114mm)	1214226
110mm x 11.25	4.33 (110mm)	1214255

DynaMc 412 HP

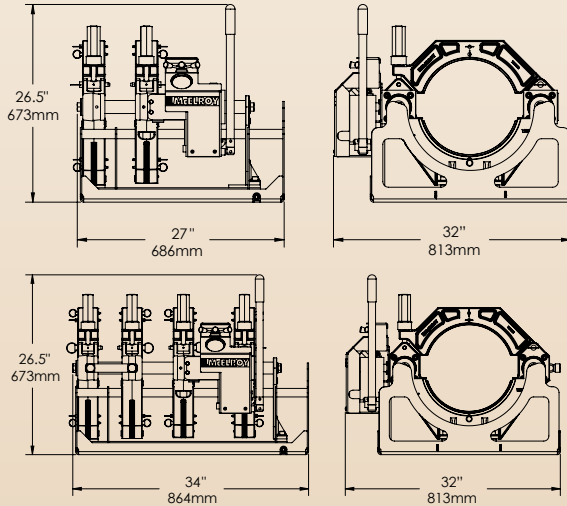

CAPACITY

Fuses Pipe Sizes: 4" IPS – 12" DIPS (110mm - 340mm)

WEIGHT

2 Jaw Machine: 200 lbs (90 kg)
 4 Jaw Machine: 293 lbs (132Kg)
 Facer: 54 lbs (24.5 kg)
 Heater: 24 lbs (10.9Kg)

HYDRAULICS

System Pressure: 1500 PSI (103 BAR) Max.

POWER

Heater Power: 3000 Watt
 Facer Power: 1.6 HP, 10 Amp @ 120V / 5 Amp @ 240V

CHASSIS

Frame: Welded aluminum construction

WARRANTY

Term: 3 Years, see page 5 for details

DynaMc 412 EP

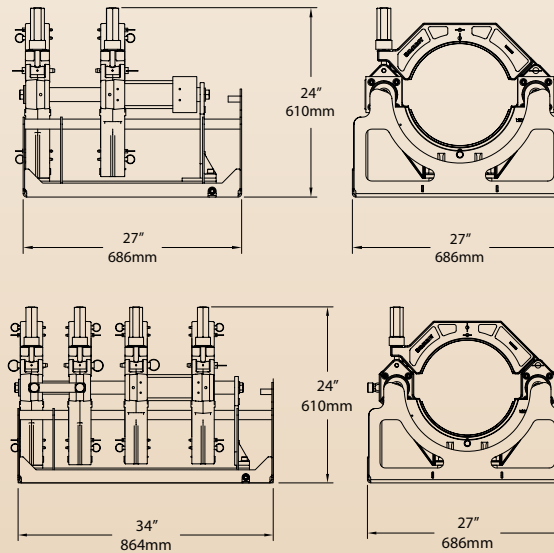

CAPACITY

Fuses Pipe Sizes: 4" IPS – 12" DIPS (110mm - 340mm)

WEIGHT

2 Jaw Machine: 170 lbs (77Kg)
 4 Jaw Machine: 263 lbs (120Kg)
 Facer: 54 lbs (24.5Kg)
 Heater: 24 lbs (10.9Kg)

POWER

Heater Power: 3000 Watt
 Facer Power: 1.6 HP, 10 Amp @ 120V / 5 Amp @ 240V

CHASSIS

Frame: Welded aluminum construction

WARRANTY

Term: 3 Years, see page 5 for details

DynaMc EP HPU

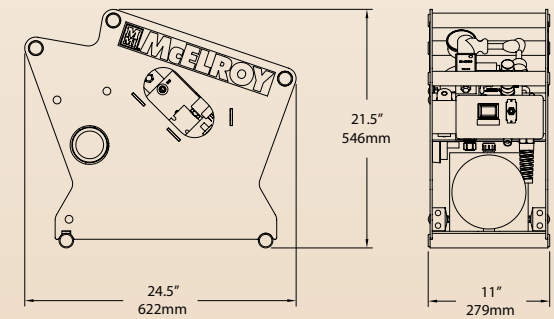

WEIGHT

Machine: 110 lbs (50Kg)

HYDRAULICS

System Pressure: 1500PSI (103 BAR) Max.

POWER

Power: 2.2 HP, 14 Amp @ 120V / 7 Amp @ 240V

CHASSIS

Frame: Welded aluminum construction

WARRANTY

Term: 3 Years, see page 5 for details

DynaMc™ 412 Specifications

DynaMc 412 Auto

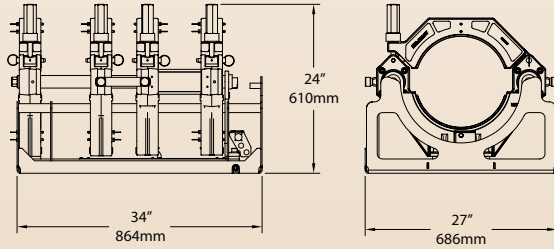

CAPACITY

Fuses Pipe Sizes: 110mm - 340mm (4" IPS - 12" DIPS)

WEIGHT

Carriage: 120Kg (263 lbs)

Minimum Carriage Transport Weight*: 70.5Kg (155 lbs)

Facer: 28.6Kg (62 lbs)

Heater: 27.2Kg (60 lbs)

POWER

Heater Power: 3000 Watt

Facer Power: Hydraulic

CHASSIS

Frame: Welded aluminum construction

WARRANTY

Term: 3 Years, see page 5 for details

DynaMc Auto HPU

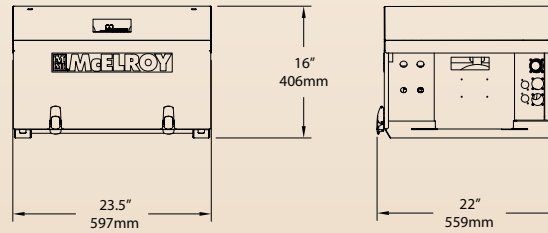

WEIGHT

Machine: 53.5Kg (118 lbs)

HYDRAULICS

System Pressure: 83 BAR (1200 PSI) Max.

POWER

Power: 4.0 HP, 28 Amp @ 110V / 14 Amp @ 220V

CHASSIS

Frame: Welded aluminum construction

WARRANTY

Term: 3 Years, see page 5 for details

* Reflects weight with upper jaws, cradle and master inserts removed.

